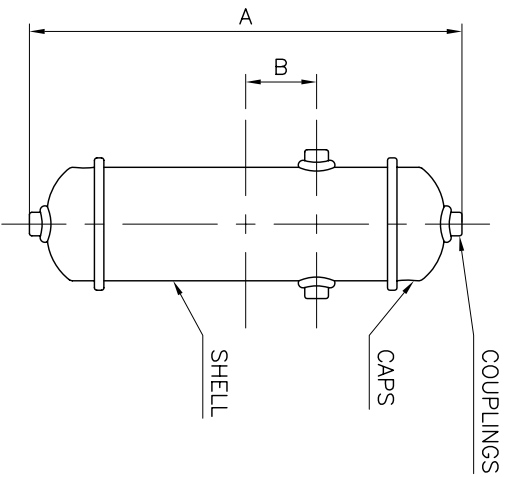

FIG.: 01



NOTES:  
 \* ALL CONNECTIONS ARE 1/2"(15) SIZE & CAN EITHER BE THREADED OR PROVIDED WITH SOCKET WELD ENDS.  
 \* THREADED CONNECTION (NPT) : AS PER ANSI B 2.1  
 \* THREADED CONNECTION (BSP) : AS PER BS 2779  
 \* SOCKET WELDING ENDS : AS PER ANSI B 16.11

MATERIAL	SHELL	CAPS
C.S.	A-106	A-105
S.S.304	A-312 TP-304	A-182 F-304
S.S.316	A-312 TP-316	A-182 F-316
A.S.	A-335 TP-22/11	A-182 F22/F11

TEST PRESSURE (Kg/cm<sup>2</sup>)

SIZE	SCH-40	SCH-80	SCH-160
3"	95	155	275
4"	90	150	260
6"	80	125	210

FIG.: 02

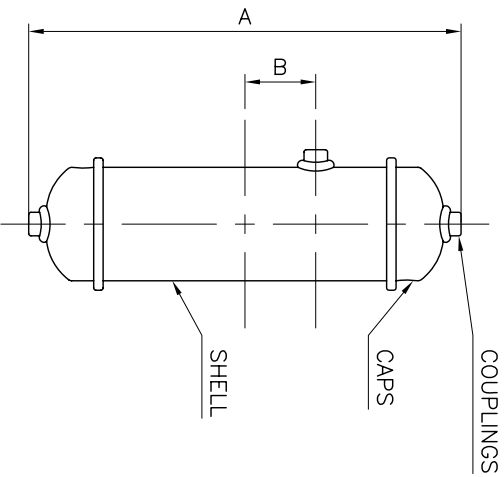

SIZE	SCHEDULE	DIMENSION 1		DIMENSION 2		DIMENSION 3		CUSTOMER REQUIREMENT	
		A	B	A	B	A	B	A	B
3"(80)	40	265	36	356	51	356	57		
	80	265	36	356	51	356	57		
	160	265	36	356	51	356	57		
4"(100)	40	265	25	356	51	356	57		
	80	265	25	356	51	356	57		
	160	265	25	356	51	356	57		
6"(150)	40			356	25	432	57		
	80			356	25	432	57		
	160			356	25	432	57		



**BAXCELL ENGINEERING**  
 PVT. LTD.

SEAL & CONDENSATE  
 CHAMBERS (POTS)

SCALE : NTS. DATE:

DRAWN BY

CHECKED BY

APPD. BY



DRG. NO. BAX-CP01

REV. R0